

WEIGHT: 0.93 lb. 0.42 Kg Max.

UNLESS OTHERWISE SPECIFIED
DIMENSIONS ARE IN INCHES
ANGLES ARE IN DEGREES
TOLERANCES:
1 DEC PLACE: ± 0.1
2 DEC PLACE: ± 0.01
3 DEC PLACE: ± 0.005
ANGLES: ± 0.5 DEG

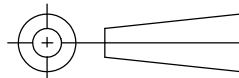

MATERIAL: N/A
FINISH: N/A

PREPARED

TAT

CHECKED

JAC
01-24-23
TAT

APPROVED

JAC
01-24-23
KDV



JUPITER AVIONICS
CORPORATION

TITLE

Six Dzus Box - Blank Faceplate

NCAGE CODE
L00N3

PART NO.
JA76-006



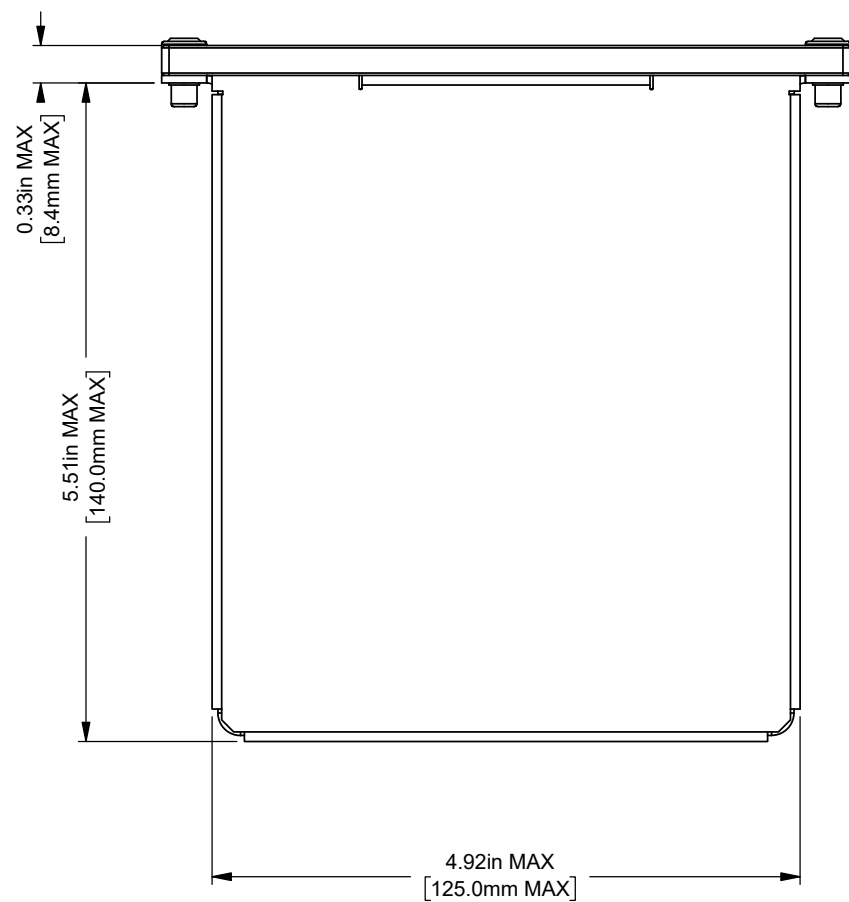
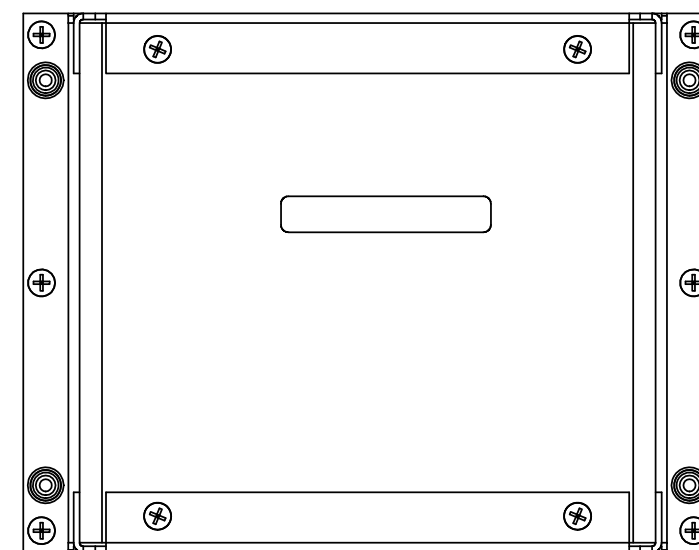
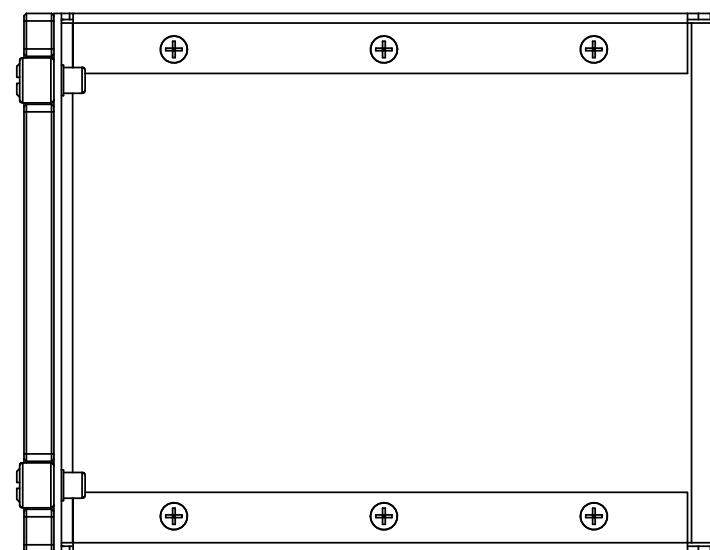
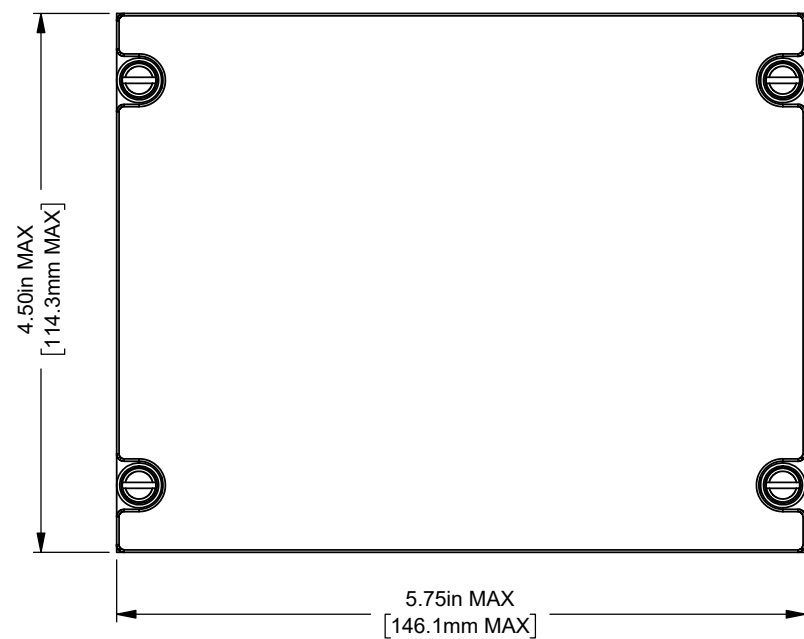

SHEET
1/1

CONFIDENTIAL & PROPRIETARY
TO JUPITER AVIONICS CORP.
DRAWING NOT TO SCALE

DOC. NO.
JA76-006 Mechanical Installation Rev B.SLDDRW



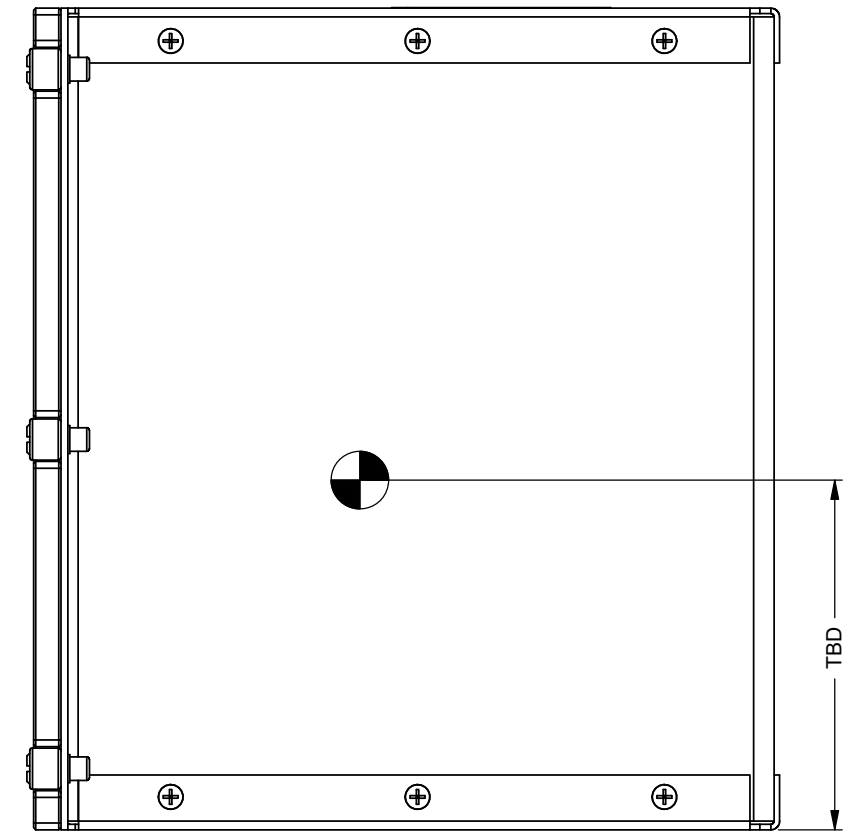
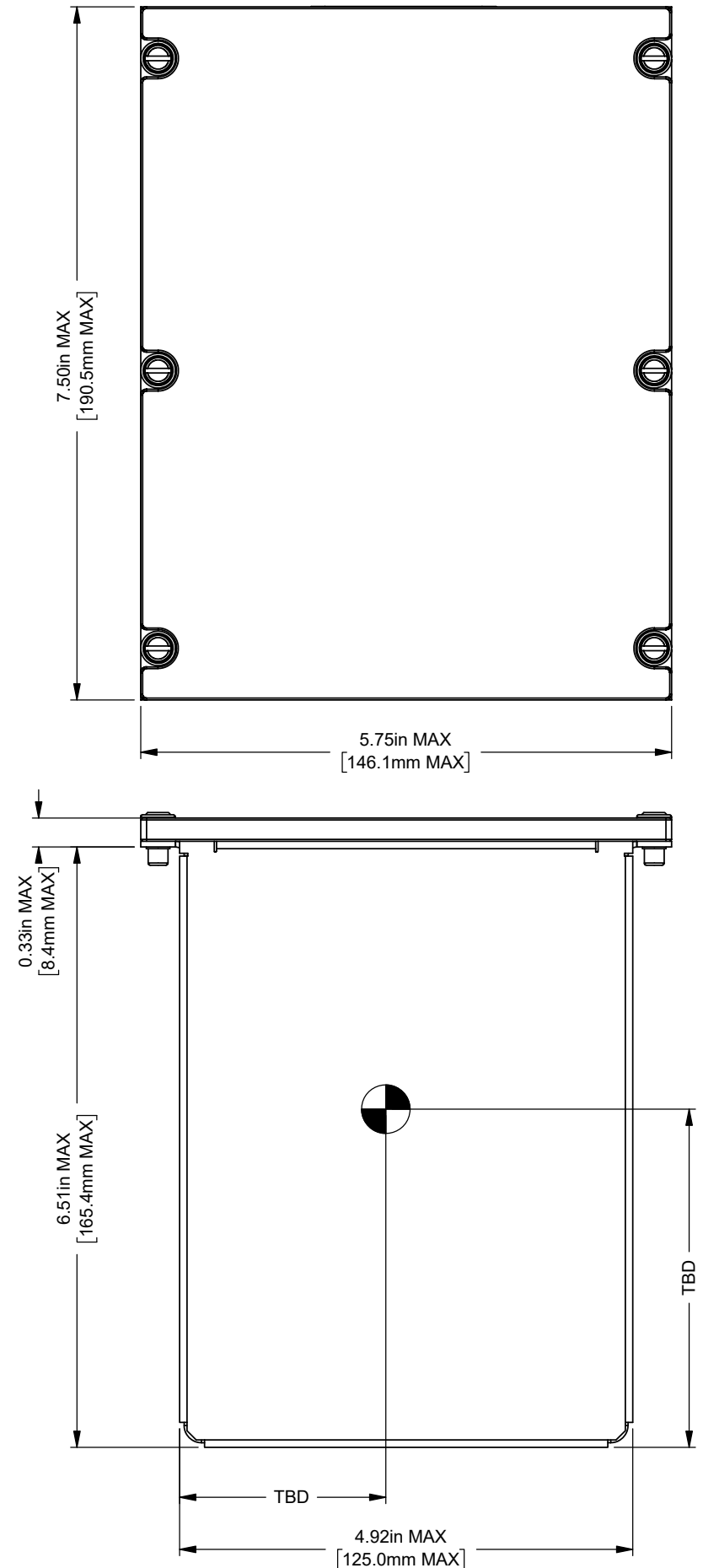

WEIGHT: 1.45 lbs [0.66 kg] MAX.

UNLESS OTHERWISE SPECIFIED DIMENSIONS ARE IN INCHES ANGLES ARE IN DEGREES TOLERANCES: 1 DEC PLACE: ± 0.1 2 DEC PLACE: ± 0.01 3 DEC PLACE: ± 0.005 ANGLES: ± 0.5 DEG	PREPARED	TAT			
	CHECKED				TITLE Twelve Dzus Box - Blank Faceplate
	APPROVED		NCAGE CODE L00N3	PART NO. JA76-012	SHEET 1/1
	MATERIAL: N/A	CONFIDENTIAL & PROPRIETARY TO JUPITER AVIONICS CORP.		DOC. NO. JA76-012 Mechanical Installation Rev A.SLDDRW	
FINISH: N/A	DRAWING NOT TO SCALE				

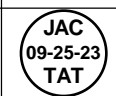

 CENTER OF GRAVITY
 ±0.03in [0.8mm]
 WEIGHT: TBD lbs [TBD kg] MAX.

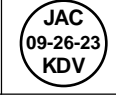
UNLESS OTHERWISE SPECIFIED DIMENSIONS ARE IN INCHES ANGLES ARE IN DEGREES TOLERANCES: 1 DEC PLACE: ± 0.1 2 DEC PLACE: ± 0.01 3 DEC PLACE: ± 0.005 ANGLES: ± 0.5 DEG	PREPARED	TAT			
	CHECKED				TITLE Twenty Dzus Box - Blank Faceplate
	APPROVED		NCAGE CODE L00N3	PART NO. JA76-020	SHEET 1/1
MATERIAL: N/A	CONFIDENTIAL & PROPRIETARY TO JUPITER AVIONICS CORP.		DOC. NO. JA76-020 Mechanical Installation Rev A.SLDDRW		
FINISH: N/A	DRAWING NOT TO SCALE				

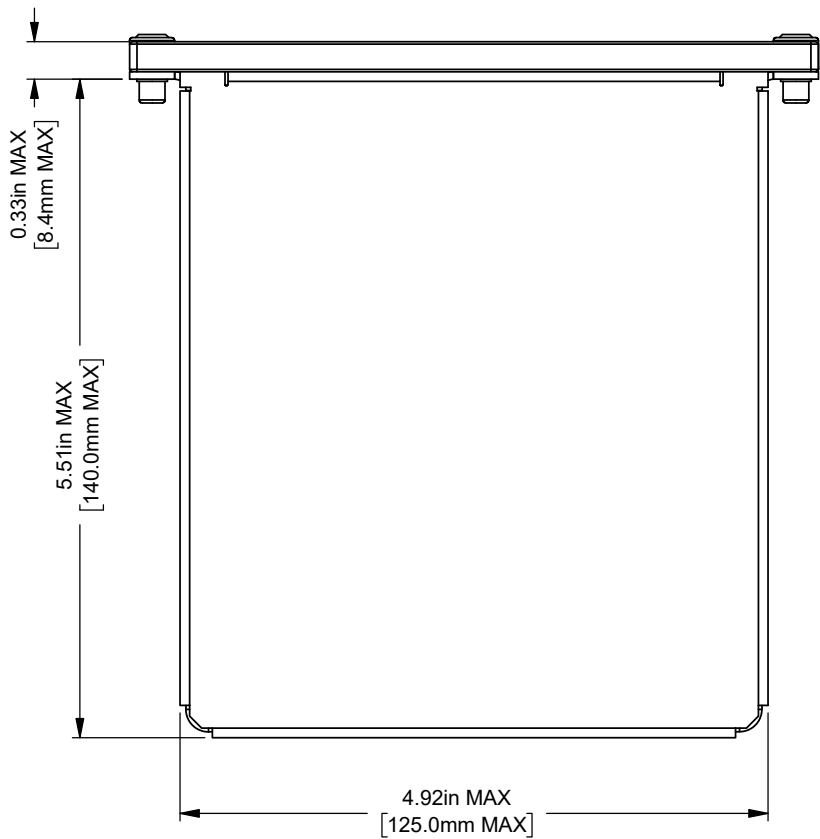
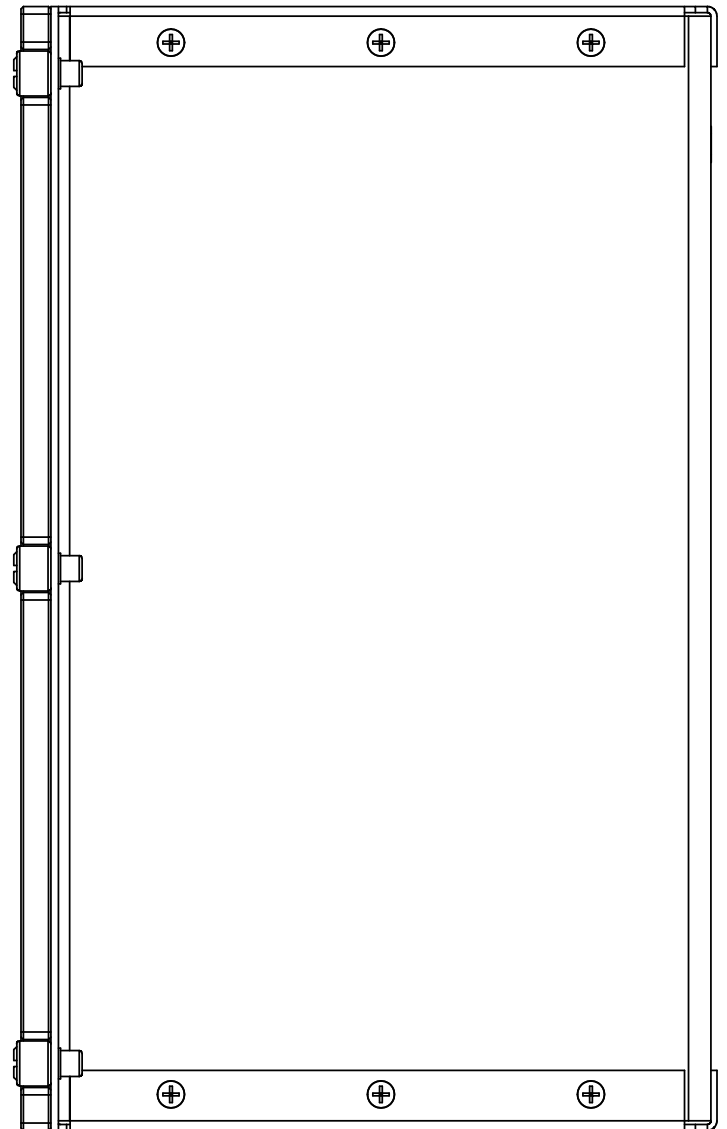
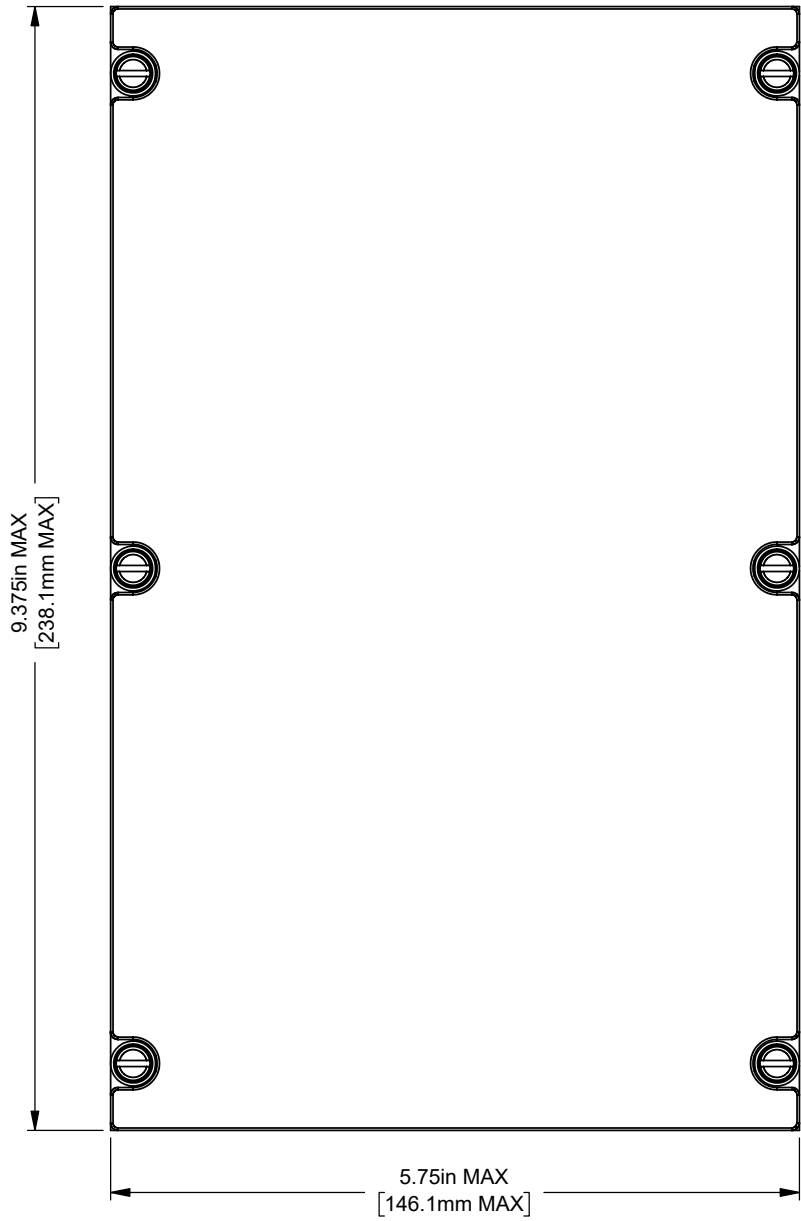

 CENTER OF GRAVITY
±0.03in [0.8mm]

WEIGHT: TBD lbs [TBD kg] MAX.

UNLESS OTHERWISE SPECIFIED
DIMENSIONS ARE IN INCHES
ANGLES ARE IN DEGREES
TOLERANCES:
1 DEC PLACE: ± 0.1
2 DEC PLACE: ± 0.01
3 DEC PLACE: ± 0.005
ANGLES: ± 0.5 DEG

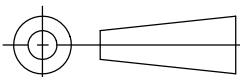

MATERIAL: N/A
FINISH: N/A

PREPARED

TAT

CHECKED

APPROVED



JUPITER AVIONICS
CORPORATION

TITLE

Twenty Five Dzus Box - Blank Faceplate

NCAGE CODE
L00N3

PART NO.
JA76-025

SHEET
1/1

CONFIDENTIAL & PROPRIETARY
TO JUPITER AVIONICS CORP.
DRAWING NOT TO SCALE

DOC. NO.
JA76-025 Mechanical Installation Rev A.SLDDRW